

PRODUCT SHEET

ENERGY PRODUCTION



ORC MODULE

ZE - 200 - LT

PLANT TECHNOLOGY

The structure of the proposed plant is based on the so-called low-temperature organic Rankine cycle (LT-ORC), and may be summed up by the diagram in **Figure 1**.

A heat source [1] generates heat, which is conveyed through a **vector fluid** circulating into a closed loop to one or more primary heat exchangers, usually a **preheater** and an **evaporator** [2], where said heat is transferred from the vector fluid to the **working fluid**.

The working fluid - a low-boiling, biodegradable, non toxic liquid when at room temperature - **boils** in the evaporator at a temperature far lower than that of water, becoming a high-pressure dry gas which spins through its expansion the impeller of a specifically designed and sized **turbine** [3].

The high-speed rotation (12.000÷18.000 Rpm) of the turbine shaft spins the rotor of a **generator** which is directly connected to it, thus producing **electric power** [4] which, after being synchronized in frequency, phase and voltage by a **power converter**, may be injected into the national power grid or self-consumed, according to local needs and policies.

Downstream the turbine, the working fluid - still in gas phase - is conveyed to another heat exchanger, called a **condenser** [5], where it is cooled, releasing its excess heat and condensing back into a liquid which is collected in a **condensation tank**, ready to be sent back to the primary heat exchanger by a **recirculation pump**, thus closing the loop.

Excess heat released in the condenser is a low-temperature thermal energy source itself, which may be **used for other purposes** such as preheating or desiccating biomass fuel (thus increasing its heating value), building heating, hot water production and so on.

In case that is not possible, residual heat may be dissipated by using an **external cooling system** [6] such as an evaporative cooling tower or a dry cooler.

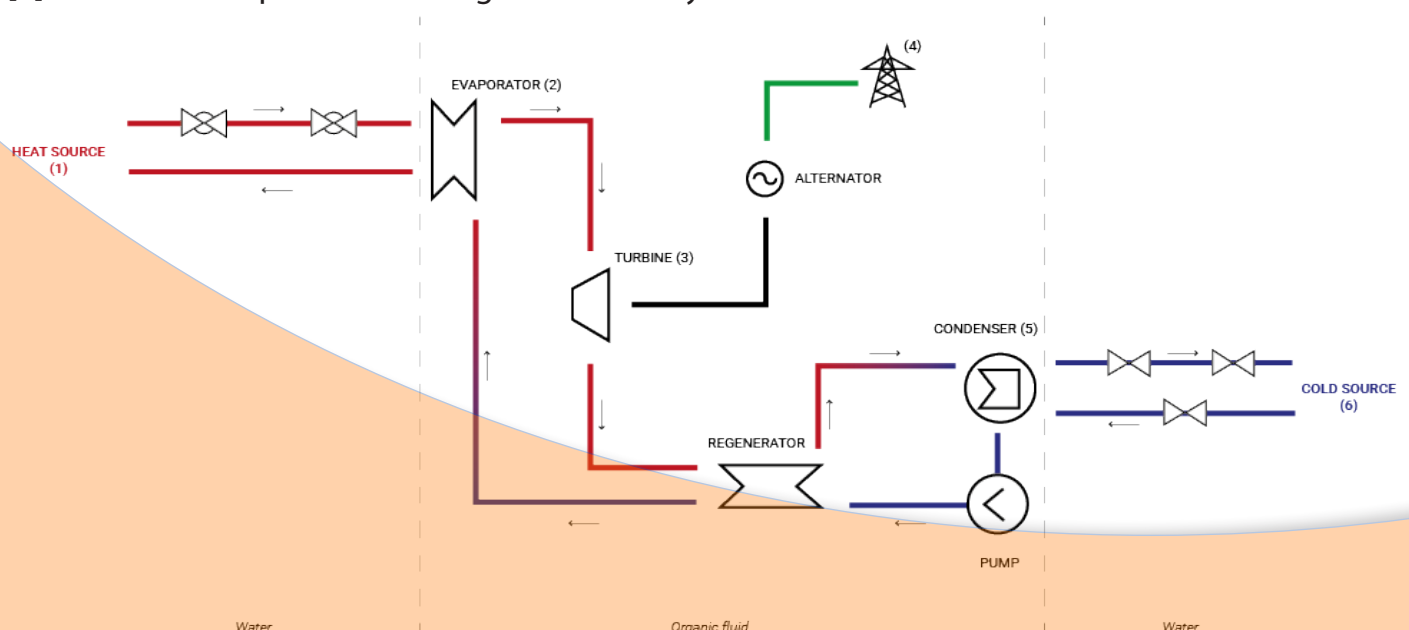
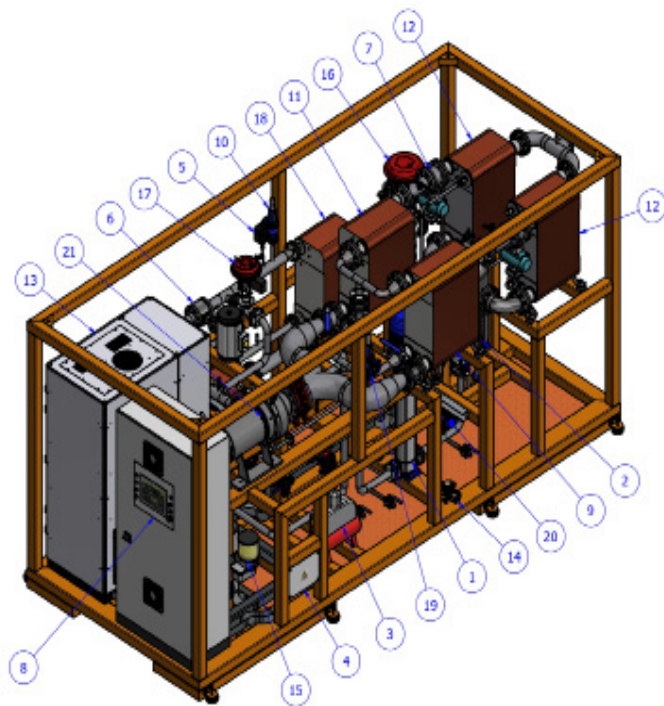

Figure 1 - Plan Diagram

ORC CIRCUIT COMPONENTS



PARTS LIST	
PART	DESCRIPTION
1	HFC FLUID PUMP
2	LEVEL METER
3	COMPRESSOR
4	ELECTRICAL CONNECTION BOX
5	SAFETY PRESSURE SWITCH
6	SAFETY VALVE STEAM
7	ON-OFF CONDENSER VALVE
8	CONTROL PANNEL
9	REGENERATOR
10	SAFETY VALVE TO CONNECT OUTSIDE DN40
11	REGENERATOR
12	CONDENSER
13	INVERTER
14	VACUUM PUMP
15	LUBRIFICATOR
16	THREE-PORT CONTROL VALVES
17	START VALVE
18	VAPORIZER
19	SECURITY VALVE DN20 X 40 FLANG Bar 8.20
20	SECURITY VALVED DN20 X 40 FLANG Bar 5.50
21	TURBINE

PROCESS DATA

WORKING FLUID	
Type	Mixture of non-toxic, non-flammable, environmental-friendly HFCs
Operational range	60-165°C
Condensation temperature	~ 33°C (@1 bar)
Working pressure	max. 20 bar
Organic vapor mass flow	~ 7.7 kg/s

HEAT EXCHANGER	
Type	Brazed plate
Working pressures	30 bar (Nominal) / 39 bar (Test) /225 bar (Burst)
Construction materials	AISI316 S/S & 99,9% copper
Max working temperature	195°C

PREHEATER + EVAPORATOR

Total thermal power input	1400 kWt
Vector fluid	Pressurized water
Vector fluid temperature (input/output)	≥ 160°C / 145°C
Vector fluid flow rate	21.65 kg/s
Electric power output from turbine	200 kWe

CONDENSER

Thermal power dissipation	1180 kWt
Condenser cooling water temperature (in/out)	26°C / 36°C
Condenser circuit flow	28.25 kg/s

TURBINE

Type	Single-stage radial inflow turbine w/fixed nozzles, directly coupled to generator shaft
Operating Temperature (Input/Output)	145°C/~100°C
Stage pressure	PS 16 (tested to 24 bar)
Materials	Machined steel (body) / Aluminium alloy (impeller)
Speed control	DC Bus Voltage
Seals and gaskets	Sealed labyrinth on impeller back and optionally at generator interface. Env. seal : Gaskets / O-rings

GENERATOR

Type	Synchronous, permanent magnet
Power Output	200 kWE
Output Voltage and Frequency	503-577 VAC @ 500 Hz
Rotational Speed	15.000 Rpm (12...18 kRpm)
Rectifier /synchronizer	Built-in / Included
Cooling system	Water jacket
Cooling fluid	Water + glycol (antifreeze) mix @ TIN<40°C

INVERTER

Type	IGBT- mains synchronized, air-cooled
Output power	200 kWE
Output voltage / frequency	380 - 480 V 3-phase 50/60Hz
Max operational environmental temperature	40°C
Braking chopper	included, 200 kW

ZE-200-LT SKID DIMENSIONS

The power generation module is supplied mounted on a self-supporting compact frame ("skid") which houses all the principal components.

The following drawings show the standard version of the ZE-200-LT ORC power generation module, designed for indoor or installation, which weighs about 6.2 tons, and fits inside a standard 40 ft High Cube container for shipping. Other versions are available, including a closed, weatherproof version for outdoor installation

