

Why ORC technology is an ideal waste heat recovery solution

Alessandro Zuccato* explains why ORC technology is an efficient and sustainable investment for a glass factory.

Glass factories are increasingly moving towards a sustainable corporate vision aimed at reducing their environmental impact. ORC technology meets this need by recovering the thermal power available in the waste gas at the furnace's outlet and adding value to it by producing electricity. This technology allows to cover a part or all the electricity self-consumption of the factory with consequent economic savings on energy consumption, which can be reinvested in the company's core business.

Working principle

The Organic Rankine Cycle (ORC) has characteristics that make it ideal for heat recovery and the exploitation of low-temperature heat sources in general. Its working principle is simple, but it is better explained through a schematic (**Fig.1**).

A heat source (1) generates heat, which is conveyed through a vector fluid circulating into a closed loop to one or more primary heat exchangers, usually a preheater and an evaporator (2), where said heat is transferred from the vector fluid to the working fluid. The working fluid - a low-boiling, biodegradable, non toxic liquid when at room temperature - boils in the evaporator at a temperature far lower than that of water, becoming a high-pressure dry gas which spins through its expansion the impeller of a specifically designed and sized turbine (3). The high-speed rotation (12.000÷18.000 rpm) of the turbine shaft spins the rotor of a generator which is directly connected to it, thus producing electric power (4) which, after being synchronised in frequency, phase and voltage by a power converter, may be injected into the national power grid or self-consumed, according to local needs and policies. Downstream the turbine, the working fluid - still in gas phase - is conveyed to another heat exchanger,

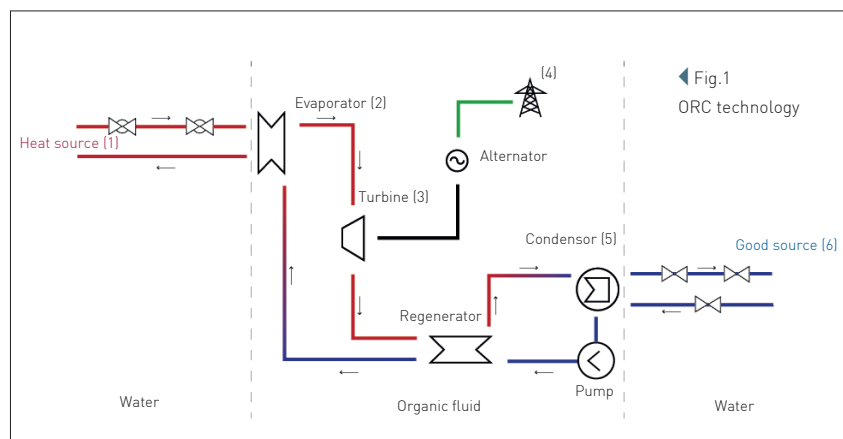

called condenser (5), where it is cooled, releasing its excess heat and condensing back into a liquid which is collected in a condensation tank, ready to be sent back to the primary heat exchanger by a recirculation pump, thus closing the loop. Excess heat released in the condenser is a low-temperature thermal energy source itself, which may be used for other purposes such as preheating or drying of biomass fuel (thus increasing its heating value), building heating, sanitary hot water production and so on. In case that is not possible, residual heat may be dissipated by using an external cooling system (6) such as an evaporative cooling tower or a dry cooler.

Glassworking applications

In hollow glass (bottles, drinking glasses, jars) manufacture it is possible to intervene in different steps of the manufacturing process: by recovering heat from flue gases upstream of the bag filter, with the bonus of cooling and stabilising filtering temperature; by recovering heat downstream of the electrostatic filter, where it is possible to perform a highly efficient heat recover from clean, relatively high-temperature fumes.

In flat glass (e.g. window pane) manufacture, it is possible instead to recover heat from the clean airflows coming from thermal stabilisation processes.

Technological and operational advantages

- **Zero Emissions.** ORC systems are impeccably eco-friendly. The entire process has zero emissions in the atmosphere, it uses an HFC working fluid and a thermal transfer fluid both completely "ozone-friendly", non-toxic, fully eco-compatible. In particular, Zuccato Energia uses plain tape water for thermal energy transfer instead of environmentally - dangerous diathermal oil.

- **Less maintenance and zero supervision.** The low operational pressures of ORC technology give great operational safety. Full-scale automatization removes the need to employ specialised personnel for operation and an integrated remote-control system grants the client full remote monitoring and management capabilities.

Continued>>



▲ Fig.2 Zuccato Energia ORC System in Area Test.

- Long duration (up to 20 years and over). ORC system has different elements that allow a long duration as the completely dry working fluid, CNC machined steel body with aluminium alloy impeller and use of ceramic bearings.
- Custom designed components. Implementation of single-stage turbines specifically designed in-house for each ORC model and custom-designed power converters (inverters) for each model guarantees maximum efficiency in energy conversion (up to 90%); extensive use of ceramic bearings grants a longer service life and maximum reliability; the direct coupling of the generator to the turbine shaft eliminates the need for a gearbox and eliminates the inherent efficiency losses.

Case study

One of the projects being completed is at Borgonovo glassworks, Italy. The factory, which covers 52,000m², produces about 45,000 tonnes of glass per year using two modern melting furnaces.

The recovery is carried out employing a heat exchanger which intercepts the fumes from the furnaces and uses them to heat some water, the vector fluid necessary for the operation of the ORC system. The fumes are cooled from a temperature of about 450 ° C up to 200 ° C while on the secondary side of the heat exchanger, pressurised water circulates at 10 bar at 140 ° C, which thanks to the heat of the fumes is heated up to 160 ° C. The system realised involves the operation of a ORC module that produces up to 200 kW of electricity. The plant is also characterised by an adiabatic cooler for the dissipation of the low-temperature heat generated by the ORC system during the production of electricity. (**Fig. 2**)

Conclusion

Environmental sustainability is the watchword of the company vision and energy consumption is the key element in assessing the environmental impact of an energy-intensive sector.

Glass factories are also moving more and more towards these values. Waste heat recovery through ORC technology becomes the means to achieve this goal: recovering heat at medium and low temperatures indeed, it allows to reduce the environmental impact of industrial processes and at the same time to reduce their economic impact allowing them to exploit their own waste and to convert them into electricity, with high flexibility and minimal maintenance requirements. ■

*CEO of Zuccato Energia, Verona, Italy
<https://zuccatoenergia.it/en/>